

OPTO-LINK TELECOM TECHNOLOGY CO.,LTD

TSPL1GCOD-xx

1.25Gb/s 120km CWDM SFP Transceiver
Hot Pluggable, Duplex LC, +3.3V, 1270nm~1610nm, CWDM DFB, Single-mode, DDM



2020/12/1



Opto-Link Telecom Technology Co., Ltd.

Lot 49G, Quang Minh Industrial Zone, Chi Dong Ward, Me Linh District, Ha Noi city, Viet Nam

Tel: +84.869.58.28.98

E-mail: Sales@optolink.vn

<http://www.optolink.vn>

Features:

- ✧ Data-rate of 1.25Gbps operation
- ✧ 18-Wavelength CWDM DFB LD Transmitter from
- ✧ 1270nm to 1610nm, with Step 20nm
- ✧ Compliant with SFP MSA and SFF-8472
- ✧ Compatible with SONET OC-24-LR-1
- ✧ Compatible with RoHS
- ✧ +3.3V single power supply
- ✧ Hot-Pluggable SFP Footprint Duplex LC
- ✧ Operating case temperature
 - Standard : 0°C to +70°C
 - Extended: -20°C to +85°C
 - Industrial: -40°C to +85°C

Applications:

- ✧ Gigabit Ethernet
- ✧ Fiber Channel Switch Infrastructure
- ✧ Router/Server interface
- ✧ Other optical transmission systems

Description:

The **TSPL1GC0D-xx** series single mode transceiver is small form factor pluggable module for duplex optical data communications such as Gigabit Ethernet 1000BASE-ZX and Fiber Channel 1x SM-LC-L FC-PI. It is with the SFP 20-pin connector to allow hot plug capability. This module is designed for single mode fiber and operates at a nominal wavelength of CWDM wavelength. There are eighteen center wavelengths available from 1270nm to 1610nm, with each step 20nm.

The transmitter section uses a multiple quantum well CWDM DFB laser and is a class 1 laser compliant according to International Safety Standard IEC-60825. The receiver section uses an integrated InGaAs detector preamplifier (IDP) mounted in an optical header and a limiting

post-amplifier IC. The **TSPL1GC0D-xx** series are designed to be compliant with SFF-8472.

● **Absolute Maximum Ratings**

Parameter	Symbol	Min.	Typical	Max.	Unit
Storage Temperature	T_S	-40		+85	°C
Supply Voltage	V_{CC}	-0.5		3.6	V
Relative Humidity	RH	0		90	%

● **Recommended Operating Environment:**

Parameter	Symbol	Min.	Typical	Max.	Unit
Case operating Temperature	T_C	0		+70	°C
Supply Voltage	V_{CC}	3.15		3.45	V
Supply Current	I_{CC}			300	mA
Data rate	GBE		1.25		Gbps
	FC		1.063		Gbps

● **Electrical Characteristics($T_{OP} = 0$ to 70°C , $V_{CC} = 3.135$ to 3.465 Volts)**

Parameter	Symbol	Min.	Typical	Max.	Unit	Note
Transmitter Section:						
Input differential impedance	R_{in}	85	100	115	Ω	
Single ended data input swing	$V_{in\ pp}$	400		2000	mVp-p	
Transmit Disable Voltage	V_D	2.0		V_{CC}	V	
Transmit Enable Voltage	V_{EN}	0		0.8	V	
Tx Fault	Fault	Tx_f	2.0		V	
	Normal	Tx_n	0		V	
Receiver Section:						
Single ended data output swing	$V_{out\ pp}$	370		1800	mv	
LOS Fault	$V_{los\ fault}$	2		V_{CC}	V	
LOS Normal	$V_{los\ norm}$	0		0.8	V	

● Optical Parameters($T_{OP} = 0$ to $70^{\circ}C$, $VCC = 3.135$ to 3.465 Volts)

Parameter	Symbol	Min.	Typical	Max.	Unit	Note
Transmitter Section:						
Center Wavelength	λ_c	$\lambda-6.5$	λ	$\lambda+6.5$	nm	
Spectral Width(-20dB)	$\Delta\lambda$			1	nm	
Side Mode Suppression Ratio	SMSR	30			dB	
Optical Output Power	P_{out}	0		+5	dBm	1
Optical Rise/Fall Time	t_r / t_f			260	ps	2
Extinction Ratio	ER	8.2			dB	
Eye Mask for Optical Output	Compliant with IEEE802.3z(class 1 laser safety)					
Receiver Section:						
Optical Input Wavelength	λ_c	1260		1620	nm	
Receiver Overload	P_{ol}	-7			dBm	3
RX Sensitivity	Sen			-32	dBm	3
RX_LOS Assert	LOS_A	-40			dBm	
RX_LOS De-assert	LOS_D			-32	dBm	
RX_LOS Hysteresis	LOS_H	0.5			dB	
General Specifications:						
Data Rate	BR		1.063/1.25		Gb/s	
Bit Error Rate	BER			10^{-12}		
Max. Supported Link Length on 9/125 μ m SMF@1.25Gb/s	L_{MAX}		120		km	
Total System Budget	LB	24			dB	

Note

1. The optical power is launched into SMF.
2. 20-80%.
3. Measured with PRBS 2^{7-1} at 10^{-12} BER

● Pin Assignment

Diagram of Host Board Connector Block Pin Numbers and Name

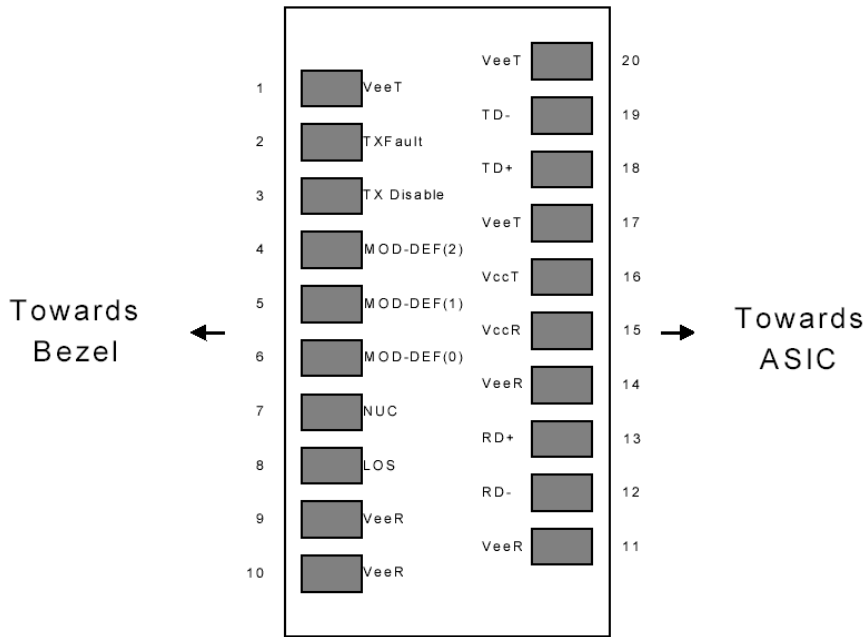

Diagram of Host Board Connector Block Pin Numbers and Names

● Pin Function Definitions

Pin No	Name	Function	Plug Seq	Notes
1	VeeT	Transmitter Ground	1	1
2	TX Fault	Transmitter Fault Indication	3	
3	TX Disable	Transmitter Disable	3	2
4	MOD-DEF2	Module Definition	2	3
5	MOD-DEF1	Module Definition 1	3	3
6	MOD-DEF0	Module Definition 0	3	3
7	Rate Select	Not Connected	3	4
8	LOS	Loss of Signal	3	5
9	VeeR	Receiver Ground	1	1
10	VeeR	Receiver Ground	1	1
11	VeeR	Receiver Ground		1
12	RD-	Inv. Received Data Out	3	6
13	RD+	Received Data Out	3	6
14	VeeR	Receiver Ground	3	1
15	VccR	Receiver Power	2	1
16	VccT	Transmitter Power	2	
17	VeeT	Transmitter Ground	1	
18	TD+	Transmit Data In	3	6

19	TD-	Inv. Transmit In	3	6
20	VeeT	Transmitter Ground	1	

Notes:

1. Circuit ground is internally isolated from chassis ground.
2. Laser output disabled on TDIS >2.0V or open, enabled on TDIS <0.8V.
3. Should be pulled up with 4.7k - 10 kohms on host board to a voltage between 2.0V and 3.6V. MOD_DEF(0) pulls line low to indicate module is plugged in.
4. Rate select is not used
5. LOS is open collector output. Should be pulled up with 4.7k – 10 kohms on host board to a voltage between 2.0V and 3.6V. Logic 0 indicates normal operation; logic 1 indicates loss of signal.
6. AC Coupled

● **SFP Module EEPROM Information and Management**

The SFP modules implement the 2-wire serial communication protocol as defined in the SFP -8472. The serial ID information of the SFP modules and Digital Diagnostic Monitor parameters can be accessed through the I²C interface at address A0h and A2h. The memory is mapped in Table 1. Detailed ID information (A0h) is listed in Table 2. And the DDM specification at address A2h. For more details of the memory map and byte definitions, please refer to the SFF-8472, “Digital Diagnostic Monitoring Interface for Optical Transceivers”. The DDM parameters have been internally calibrated.

Table 1. Digital Diagnostic Memory Map (Specific Data Field Descriptions)

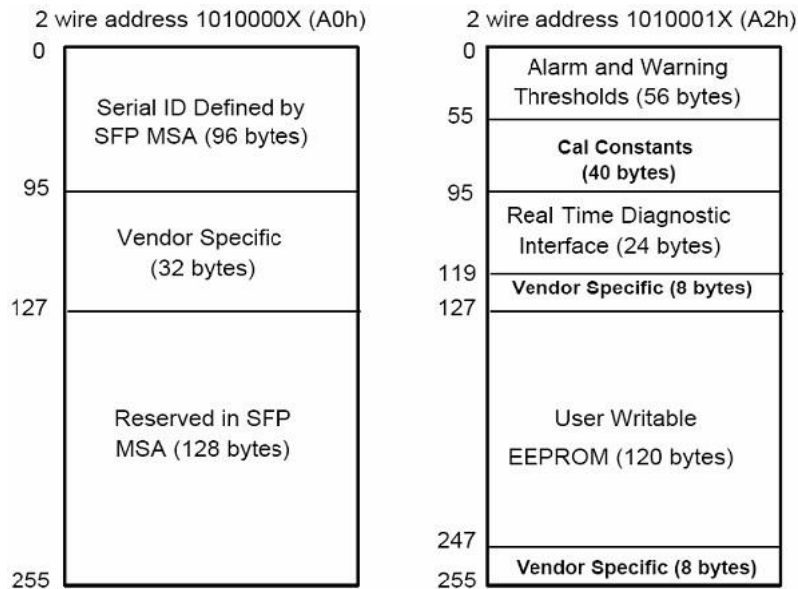

Table 2 - EEPROM Serial ID Memory Contents (A0h)

Data Address	Length (Byte)	Name of Length	Description and Contents
--------------	---------------	----------------	--------------------------

Base ID Fields			
0	1	Identifier	Type of Serial transceiver (03h=SFP)
1	1	Reserved	Extended identifier of type serial transceiver (04h)
2	1	Connector	Code of optical connector type (07=LC)
3-10	8	Transceiver	
11	1	Encoding	NRZ(03h)
12	1	BR, Nominal	Nominal baud rate, unit of 100Mbps
13-14	2	Reserved	(0000h)
15	1	Length(9um)	Link length supported for 9/125um fiber, units of 100m
16	1	Length(50um)	Link length supported for 50/125um fiber, units of 10m
17	1	Length(62.5um)	Link length supported for 62.5/125um fiber, units of 10m
18	1	Length(Copper)	Link length supported for copper, units of meters
19	1	Reserved	
20-35	16	Vendor Name	SFP vendor name: OPTO-LINK
36	1	Reserved	
37-39	3	Vendor OUI	SFP transceiver vendor OUI ID
40-55	16	Vendor PN	Part Number: "TSPL1GC0D-xx" (ASCII)
56-59	4	Vendor rev	Revision level for part number
60-62	3	Reserved	
63	1	CCID	Least significant byte of sum of data in address 0-62
Extended ID Fields			
64-65	2	Option	Indicates which optical SFP signals are implemented (001Ah = LOS, TX_FAULT, TX_DISABLE all supported)
66	1	BR, max	Upper bit rate margin, units of %
67	1	BR, min	Lower bit rate margin, units of %
68-83	16	Vendor SN	Serial number (ASCII)
84-91	8	Date code	OPTO-LINK's Manufacturing date code
92-94	3	Reserved	
95	1	CCEX	Check code for the extended ID Fields (addresses 64 to 94)
Vendor Specific ID Fields			
96-127	32	Readable	OPTO-LINK specific date, read only
128-255	128	Reserved	Reserved for SFF-8079

● Digital Diagnostic Monitor Characteristics

Data Address	Parameter	Accuracy	Unit
--------------	-----------	----------	------

96-97	Transceiver Internal Temperature	±3.0	°C
98-99	VCC3 Internal Supply Voltage	±3.0	%
100-101	Laser Bias Current	±10	%
102-103	Tx Output Power	±3.0	dBm
104-105	Rx Input Power	±3.0	dBm

● Regulatory Compliance

The **TSPL1GC0D-xx** complies with international Electromagnetic Compatibility (EMC) and international safety requirements and standards (see details in Table following).

Electrostatic Discharge (ESD) to the Electrical Pins	MIL-STD-883E Method 3015.7	Class 1(>1000 V)
Electrostatic Discharge (ESD) to the Duplex LC Receptacle	IEC 61000-4-2 GR-1089-CORE	Compatible with standards
Electromagnetic Interference (EMI)	FCC Part 15 Class B EN55022 Class B (CISPR 22B) VCCI Class B	Compatible with standards
Laser Eye Safety	FDA 21CFR 1040.10 and 1040.11 EN60950, EN (IEC) 60825-1,2	Compatible with Class 1 laser product.

● Recommended Circuit

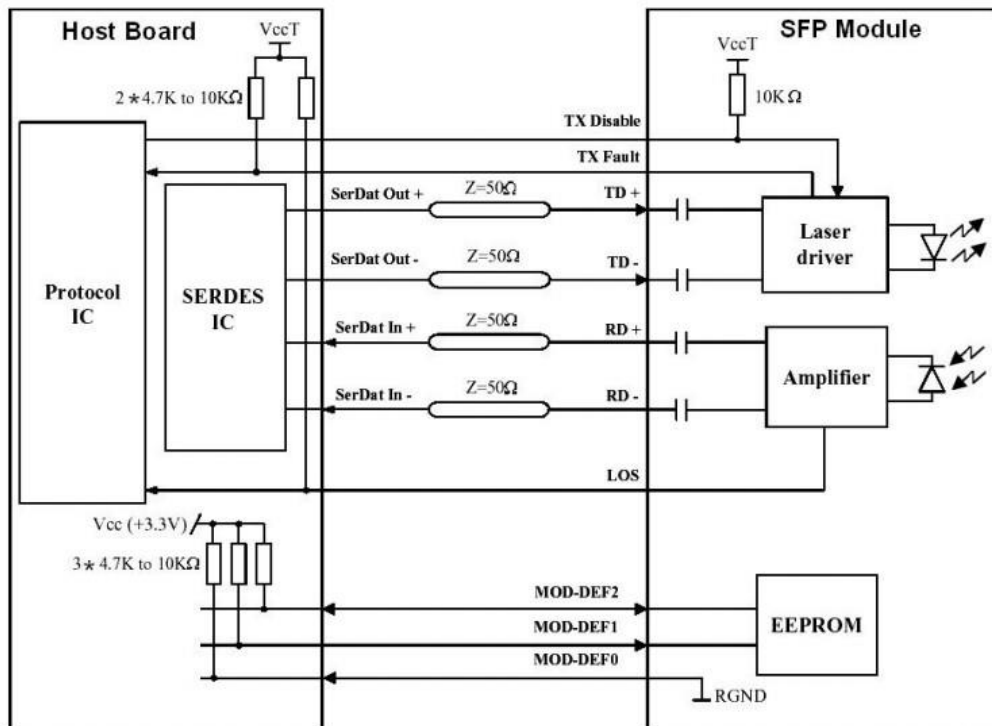

SFP Host Recommended Circuit

● Mechanical Dimensions

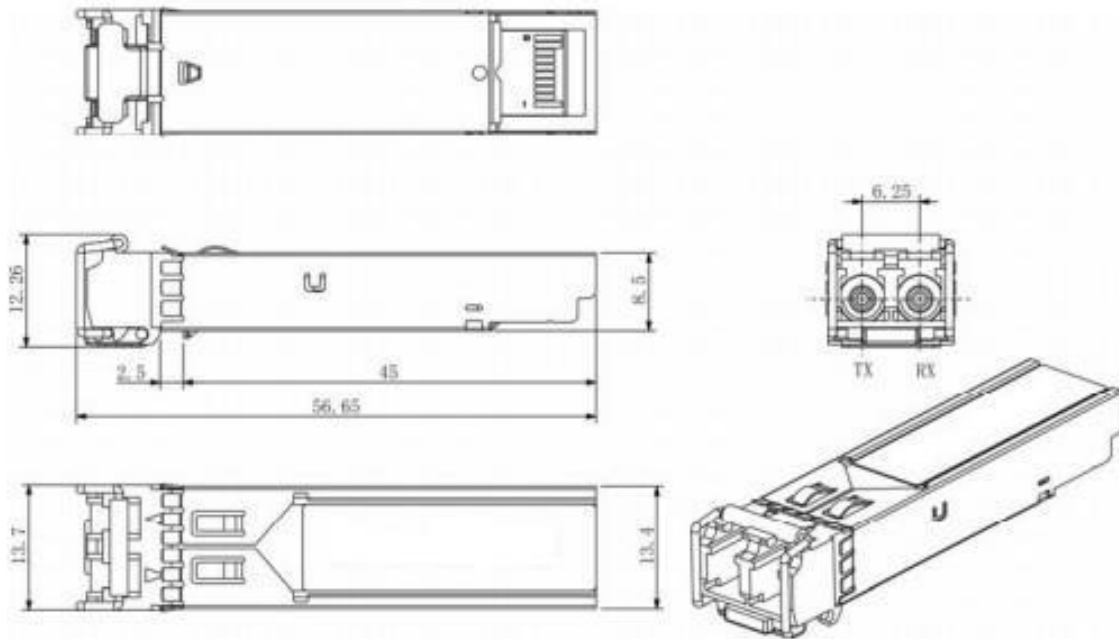

Mechanical Drawing

● Order Information:

In the Part No. of TSPL1GC0D-xx, xx stands for central wavelength, such as:

27: for 1270nm, 29: for 1290nm, 31: for 1310nm,..... 61: for 1610nm.